

MF-V060-A

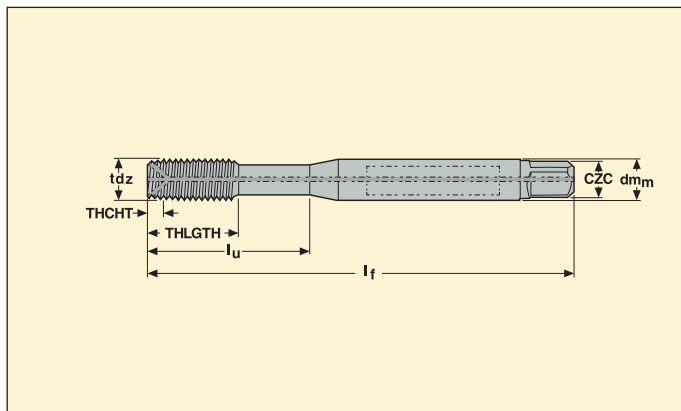

- Раскатники
- По режимам обработки см. стр. 276
- Покрытие TiN
- A = Внутренняя подача СОЖ
- Материал HSS-E

Обозначение	Резьба	Шаг		Размеры в мм					Число зубьев	BSG	tctr	THCHT
		mm	TPI	dm _m	lu	THLGTH	lf	CZC				
MF- M5X0.80ISO6HX-XC-V060-A	M5	0,8	—	6,00	21	13	70	6.00X4.90	—	DIN 2174	6HX	C
MF- M6X1.00ISO6HX-XC-V060-A	M6	1	—	6,00	26	15	80	6.00X4.90	—	DIN 2174	6HX	C
MF- M8X1.25ISO6HX-XC-V060-A	M8	1,25	—	8,00	30	18	90	8.00X6.20	—	DIN 2174	6HX	C
MF- M10X1.50ISO6HX-XC-V060-A	M10	1,5	—	10,00	33	20	100	10.00X8.00	—	DIN 2174	6HX	C
MF- M12X1.75ISO6HX-XC-V060-A	M12	1,75	—	9,00	83	23	110	9.00X7.00	—	DIN 2174	6HX	C

Пожалуйста, уточняйте наличие на складе действующую цену.

MF-V063



- Раскатники
- По режимам обработки см. стр. 276
- Покрытие TiN
- Материал HSS-E

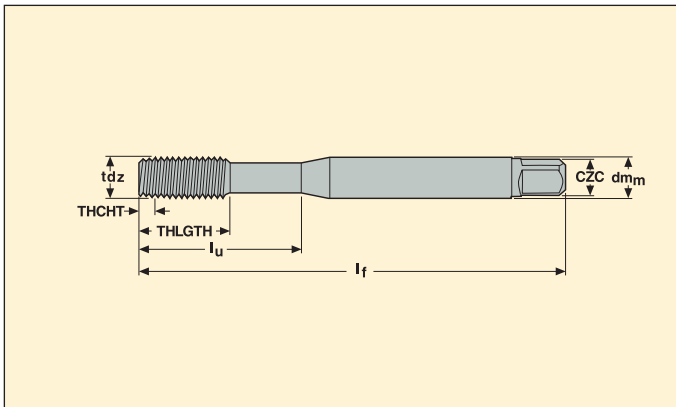

Обозначение	Резьба	Шар		Размеры в мм						Число зубьев	BSG	tctr	THCHT
		mm	TPI	dm _m	lu	THLGTH	lf	CZC					
MF- M5X0.50ISO6HX-XC-V063	MF5x0.5	0,5	-	6,00	25	13	70	6.00X4.90	-	DIN 2174	6HX	C	
MF- M6X0.75ISO6HX-XC-V063	MF6x0.75	0,75	-	6,00	30	15	80	6.00X4.90	-	DIN 2174	6HX	C	
MF- M7X0.75ISO6HX-XC-V063	MF7x0.75	0,75	-	7,00	30	15	80	7.00X5.50	-	DIN 2174	6HX	C	
MF- M8X0.75ISO6HX-XC-V063	MF8x0.75	0,75	-	6,00	57	18	80	6.00X4.90	-	DIN 2174	6HX	C	
MF- M8X1.00ISO6HX-XC-V063	MF8x1.0	1	-	6,00	67	18	90	6.00X4.90	-	DIN 2174	6HX	C	
MF- M10X1.00ISO6HX-XC-V063	MF10x1.0	1	-	7,00	75	20	100	7.00X5.50	-	DIN 2174	6HX	C	
MF- M10X1.25ISO6HX-XC-V063	MF10x1.25	1,25	-	7,00	75	20	100	7.00X5.50	-	DIN 2174	6HX	C	
MF- M12X1.00ISO6HX-XC-V063	MF12x1.0	1	-	9,00	73	23	100	9.00X7.00	-	DIN 2174	6HX	C	
MF- M12X1.25ISO6HX-XC-V063	MF12x1.25	1,25	-	9,00	73	23	100	9.00X7.00	-	DIN 2174	6HX	C	
MF- M12X1.50ISO6HX-XC-V063	MF12x1.5	1,5	-	9,00	73	23	100	9.00X7.00	-	DIN 2174	6HX	C	
MF- M14X1.00ISO6HX-XC-V063	MF14x1.0	1	-	11,00	71	21	100	11.00X9.00	-	DIN 2174	6HX	C	
MF- M14X1.25ISO6HX-XC-V063	MF14x1.25	1,25	-	11,00	71	21	100	11.00X9.00	-	DIN 2174	6HX	C	
MF- M14X1.50ISO6HX-XC-V063	MF14x1.5	1,5	-	11,00	71	21	100	11.00X9.00	-	DIN 2174	6HX	C	
MF- M16X1.50ISO6HX-XC-V063	MF16x1.5	1,5	-	12,00	58	21	100	12.00X9.00	-	DIN 2174	6HX	C	

Пожалуйста, уточняйте наличие на складе действующую цену.