

Metric coarse thread for inserts EG M

Tolerance 6H mod

N° E11970 / E11971



HSS-E
Co5



Rm
<850

Al
Aluminium
Alloy

341

N° E11980 / E11981



HSS-E
Co5



Rm
<850

Al
Aluminium
Alloy

343

Application

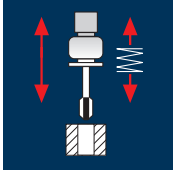

Material

Steel
< 500 N/mm²

EG-M	ø [mm]	P [mm]	V _c 1.5 x d			V _c 2.0 x d			V _c 3.0 x d		
			n [min ⁻¹]	v _f [100%]		n [min ⁻¹]	v _f [100%]		n [min ⁻¹]	v _f [100%]	
EGM 2	2.520	0.40	14	1770	708	12	1515	606	10	1265	506
EGM 2.5	3.084	0.45	14	1445	650	12	1240	558	10	1030	464
EGM 3	3.650	0.50	14	1220	610	12	1045	523	10	870	435
EGM 4	4.910	0.70	14	910	637	12	780	546	10	650	455
EGM 5	6.040	0.80	14	740	592	12	630	504	10	525	420
EGM 6	7.300	1.00	14	610	610	12	525	525	10	435	435
EGM 8	9.624	1.25	14	465	581	12	395	494	10	330	413
EGM 10	11.948	1.50	14	375	563	12	320	480	10	265	398
EGM 12	14.274	1.75	14	310	543	12	270	473	10	225	394

Steel
< 500 N/mm²

EGM 14	16.598	2.00	14	270	540	12	230	460	10	190	380
EGM 16	18.598	2.00	14	240	480	12	205	410	10	170	340

Steel
500 - 850 N/mm²

EGM 2	2.520	0.40	10	1265	506	8	1010	404	6	760	304
EGM 2.5	3.084	0.45	10	1030	464	8	825	371	6	620	279
EGM 3	3.650	0.50	10	870	435	8	700	350	6	525	263
EGM 4	4.910	0.70	10	650	455	8	520	364	6	390	273
EGM 5	6.040	0.80	10	525	420	8	420	336	6	315	252
EGM 6	7.300	1.00	10	435	435	8	350	350	6	260	260
EGM 8	9.624	1.25	10	330	413	8	265	331	6	200	250
EGM 10	11.948	1.50	10	265	398	8	215	323	6	160	240
EGM 12	14.274	1.75	10	225	394	8	180	315	6	135	236

Steel
500 - 850 N/mm²

EGM 14	16.598	2.00	10	190	380	8	155	310	6	115	230
EGM 16	18.598	2.00	10	170	340	8	135	270	6	105	210

Material

Wrought aluminium
alloys Si < 6%
hardened

EG-M	ø [mm]	P [mm]	V _c 1.5 x d			V _c 2.0 x d			V _c 3.0 x d		
			n [min ⁻¹]	v _f [100%]		n [min ⁻¹]	v _f [100%]		n [min ⁻¹]	v _f [100%]	
EGM 2	2.520	0.40	11	1390	556	9	1135	454	7	885	354
EGM 2.5	3.084	0.45	11	1135	511	9	930	419	7	720	324
EGM 3	3.650	0.50	11	960	480	9	785	393	7	610	305
EGM 4	4.910	0.70	11	715	500	9	585	410	7	455	319
EGM 5	6.040	0.80	11	580	464	9	475	380	7	370	296
EGM 6	7.300	1.00	11	480	480	9	390	390	7	305	305
EGM 8	9.624	1.25	11	365	456	9	300	375	7	230	288
EGM 10	11.948	1.50	11	295	443	9	240	360	7	185	278
EGM 12	14.274	1.75	11	245	429	9	200	350	7	155	271

Wrought aluminium
alloys Si < 6%
hardened

EGM 14	16.598	2.00	11	210	420	9	175	350	7	135	270
EGM 16	18.598	2.00	11	190	380	9	155	310	7	120	240

Unalloyed copper

EGM 2	2.520	0.40	12	1515	606	10	1265	506	8	1010	404
EGM 2.5	3.084	0.45	12	1240	558	10	1030	464	8	825	371
EGM 3	3.650	0.50	12	1045	523	10	870	435	8	700	350
EGM 4	4.910	0.70	12	780	546	10	650	455	8	520	364
EGM 5	6.040	0.80	12	630	504	10	525	420	8	420	336
EGM 6	7.300	1.00	12	525	525	10	435	435	8	350	350
EGM 8	9.624	1.25	12	395	494	10	330	413	8	265	331
EGM 10	11.948	1.50	12	320	480	10	265	398	8	215	323
EGM 12	14.274	1.75	12	270	473	10	225	394	8	180	315

Unalloyed copper

EGM 14	16.598	2.00	12	230	460	10	190	380	8	155	310
EGM 16	18.598	2.00	12	205	410	10	170	340	8	135	270

Taps for inserts



EG M **6H mod**

HSS-E Co5

DIN 371/376

Form B

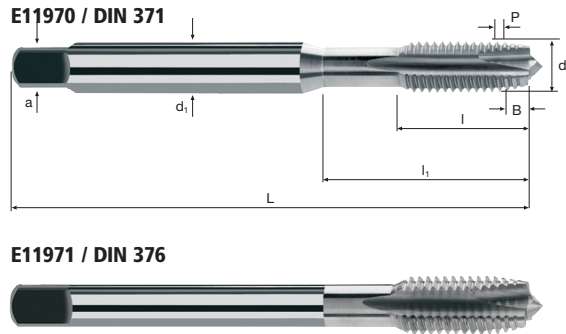

Rm < 850 **Al** Aluminium > 99% **Al** Aluminium Alloy **Al** Aluminium Cast **Cu** Copper **Plastic** Thermoplast **GG(G)**

Example: Order-N°.										Article-N°.		ø-Code	
										E11970		.034	
Ø Code	d	P	L	l	l ₁	d ₁	a						
.034	EGM 2	0.40	50	9	15	2.8	2.1	2	2.15	●			
.040	EGM 2.5	0.45	56	12	18	3.5	2.7	3	2.65	●			
.044	EGM 3	0.50	63	13	21	4.5	3.0	3	3.15	●			
.058	EGM 4	0.70	70	15	25	6.0	4.9	3	4.20	●			
.084	EGM 5	0.80	80	17	30	6.0	4.9	3	5.25	●			
.088	EGM 6	1.00	90	20	35	8.0	6.2	3	6.30	●			
.160	EGM 8	1.25	100	22	39	10.0	8.0	3	8.40	●			

Example: Order-N°.										Article-N°.		ø-Code	
										E11971		.174	
Ø Code	d	P	L	l	l ₁	d ₁	a						
.174	EGM10	1.50	110	24	40	9.0	7.0	3	10.40	●			
.240	EGM12	1.75	110	26	40	11.0	9.0	3	12.50	●			
.244	EGM14	2.00	110	27	40	12.0	9.0	4	14.50	●			
.246	EGM16	2.00	125	30	65	14.0	11.0	4	16.50	●			

EG

Application

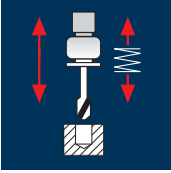

Material

Steel
< 500 N/mm²

EG-M	ø [mm]	P [mm]	V _c			n			v _f		
			1.0 x d	[min ⁻¹]	[100%]	1.5 x d	[min ⁻¹]	[100%]	2.0 x d	[min ⁻¹]	[100%]
EGM 2	2.520	0.40	11	1390	556	10	1265	506	8	1010	404
EGM 2.5	3.084	0.45	11	1135	511	10	1030	464	8	825	371
EGM 3	3.650	0.50	11	960	480	10	870	435	8	700	350
EGM 4	4.910	0.70	11	715	500	10	650	455	8	520	364
EGM 5	6.040	0.80	11	580	464	10	525	420	8	420	336
EGM 6	7.300	1.00	11	480	480	10	435	435	8	350	350
EGM 8	9.624	1.25	11	365	456	10	330	413	8	265	331
EGM 10	11.948	1.50	11	295	443	10	265	398	8	215	323
EGM 12	14.274	1.75	11	245	429	10	225	394	8	180	315

Steel
< 500 N/mm²

EGM 14	16.598	2.00	11	210	420	10	190	380	8	155	310
EGM 16	18.598	2.00	11	190	380	10	170	340	8	135	270

Steel
500 - 850 N/mm²

EGM 2	2.520	0.40	8	1010	404	7	885	354	6	760	304
EGM 2.5	3.084	0.45	8	825	371	7	720	324	6	620	279
EGM 3	3.650	0.50	8	700	350	7	610	305	6	525	263
EGM 4	4.910	0.70	8	520	364	7	455	319	6	390	273
EGM 5	6.040	0.80	8	420	336	7	370	296	6	315	252
EGM 6	7.300	1.00	8	350	350	7	305	305	6	260	260
EGM 8	9.624	1.25	8	265	331	7	230	288	6	200	250
EGM 10	11.948	1.50	8	215	323	7	185	278	6	160	240
EGM 12	14.274	1.75	8	180	315	7	155	271	6	135	236

Steel
500 - 850 N/mm²

EGM 14	16.598	2.00	8	155	310	7	135	270	6	115	230
EGM 16	18.598	2.00	8	135	270	7	120	240	6	105	210

Material

Wrought aluminium
alloys Si < 6%
hardened

EG-M	ø [mm]	P [mm]	V _c			n			v _f		
			1.0 x d	[min ⁻¹]	[100%]	1.5 x d	[min ⁻¹]	[100%]	2.0 x d	[min ⁻¹]	[100%]
EGM 2	2.520	0.40	7	885	354	6	760	304	6	760	304
EGM 2.5	3.084	0.45	7	720	324	6	620	279	6	620	279
EGM 3	3.650	0.50	7	610	305	6	525	263	6	525	263
EGM 4	4.910	0.70	7	455	319	6	390	273	6	390	273
EGM 5	6.040	0.80	7	370	296	6	315	252	6	315	252
EGM 6	7.300	1.00	7	305	305	6	260	260	6	260	260
EGM 8	9.624	1.25	7	230	288	6	200	250	6	200	250
EGM 10	11.948	1.50	7	185	278	6	160	240	6	160	240
EGM 12	14.274	1.75	7	155	271	6	135	236	6	135	236

Wrought aluminium
alloys Si < 6%
hardened

EGM 14	16.598	2.00	7	135	270	6	115	230	6	115	230
EGM 16	18.598	2.00	7	120	240	6	105	210	6	105	210

Unalloyed copper

EGM 2	2.520	0.40	10	1265	506	9	1135	454	8	1010	404
EGM 2.5	3.084	0.45	10	1030	464	9	930	419	8	825	371
EGM 3	3.650	0.50	10	870	435	9	785	393	8	700	350
EGM 4	4.910	0.70	10	650	455	9	585	410	8	520	364
EGM 5	6.040	0.80	10	525	420	9	475	380	8	420	336
EGM 6	7.300	1.00	10	435	435	9	390	390	8	350	350
EGM 8	9.624	1.25	10	330	413	9	300	375	8	265	331
EGM 10	11.948	1.50	10	265	398	9	240	360	8	215	323
EGM 12	14.274	1.75	10	225	394	9	200	350	8	180	315

Unalloyed copper

EGM 14	16.598	2.00	10	190	380	9	175	350	8	155	310
EGM 16	18.598	2.00	10	170	340	9	155	310	8	135	270

Taps for inserts



EG M **6H mod**

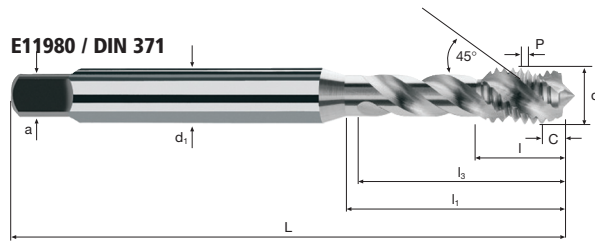
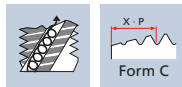

E11981 / DIN 376



Rm < 850		Al Aluminium > 99%	Al Aluminium Alloy	Al Aluminium Cast		Cu Copper	Plastic Thermoplast	GG(G)
--------------------	--	---------------------------------	---------------------------------	--------------------------------	--	---------------------	-------------------------------	--------------

Example: Order-N°.											Article-N°.		ø-Code	
											E11980		.034	
Ø Code	d	P	L	l	l ₁	l ₂	d ₁	a						
.034	EGM 2	0.40	50	9.0	15	13	2.8	2.1	3	2.15	●			
.040	EGM 2.5	0.45	56	4.0	18	16	3.5	2.7	3	2.65	●			
.044	EGM 3	0.50	63	5.6	21	19	4.5	3.0	3	3.15	●			
.058	EGM 4	0.70	70	6.4	25	23	6.0	4.9	3	4.20	●			
.084	EGM 5	0.80	80	8.0	30	28	6.0	4.9	3	5.25	●			
.088	EGM 6	1.00	90	10.0	35	33	8.0	6.2	3	6.30	●			
.160	EGM 8	1.25	100	12.0	39	37	10.0	8.0	3	8.40	●			

Example: Order-N°.											Article-N°.		ø-Code	
											E11981		.174	
Ø Code	d	P	L	l	l ₁	l ₂	d ₁	a						
.174	EGM10	1.50	110	14.0	50	48	9.0	7.0	3	10.40	●			
.240	EGM12	1.75	110	16.0	58	56	11.0	9.0	4	12.50	●			
.244	EGM14	2.00	110	16.0	58	56	12.0	9.0	4	14.50	●			
.246	EGM16	2.00	125	20.0	65	63	14.0	11.0	4	16.50	●			

EG