

Серия **3011**

Метчики PG ручные по сталям, чугуну, цветным металлам и алюминию

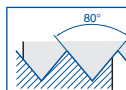

Steel Electric Pipe Thread

HSS	DIN 40432	C 2-3h		α $10^\circ \pm 2$	№3 Чистовой
-----	-----------	--------	--	------------------------------	----------------

Группа 1 Подгр. 1.1	Группа 5 Подгр. 5.1	Группа 3 Подгр. 3.1/3.2	Группа 6 Подгр. 6.1/6.2/6.3
------------------------	------------------------	----------------------------	--------------------------------

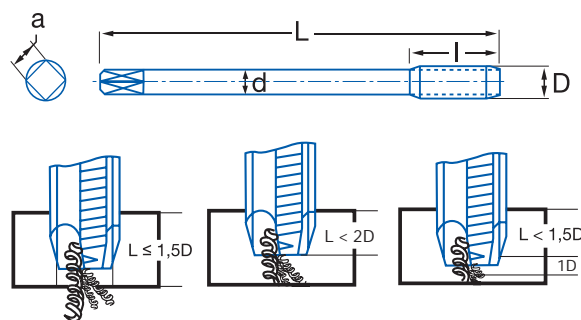

PG	D mm	Кол-во ниток	L mm	l mm	d mm	a mm	Z	№ Art. HSS	€
PG 07	12,50	20	70	22	9	7,00	4	38291	23,28
PG 09	15,20	18	70	22	12	9,00	4	38292	29,58
PG 11	18,60	18	80	22	14	11,00	4	38293	41,09
PG 13,5	20,40	18	80	22	16	12,00	4	38294	45,06
PG 16	22,50	18	80	22	18	14,50	4	38295	54,10
PG 21	28,30	16	90	22	22	18,00	5	38296	79,57
PG 29	37,00	16	100	25	28	22,00	5	38297	157,97
PG 36	47,00	16	140	40	36	29,00	6	38298	263,88
PG 42	54,00	16	140	40	40	32,00	8	38299	313,38
PG 48	59,30	16	160	40	45	35,00	8	38300	395,20