

MTH-V045

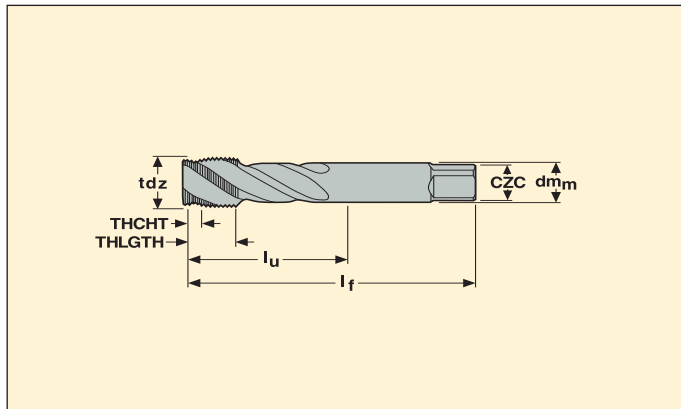

- По режимам обработки см. стр. 276
- Покрытие TiN
- Материал HSS-PM ≤ G3/8, HSS-E > G3/8

Обозначение	Резьба	Шаг		Размеры в мм					Число зубьев	BSG	tctr	THCHT
		mm	TPI	dm _m	lu	THLGTH	lf	Czc				
MTH- 1/8-28G-BC-V045	G 1/8-28	-	28	7,00	67	13	90	7.00X5.50	3	DIN 5156	NORMAL	C
MTH- 1/4-19G-BC-V045	G 1/4-19	-	19	11,00	71	15	100	11.00X9.00	3	DIN 5156	NORMAL	C
MTH- 3/8-19G-BC-V045	G 3/8-19	-	19	12,00	58	15	100	12.00X9.00	4	DIN 5156	NORMAL	C
MTH- 1/2-14G-BC-V045	G 1/2-14	-	14	16,00	80	18	125	16.00X12.00	4	DIN 5156	NORMAL	C
MTH- 5/8-14G-BC-V045	G 5/8-14	-	14	18,00	78	18	125	18.00X14.50	4	DIN 5156	NORMAL	C
MTH- 3/4-14G-BC-V045	G 3/4-14	-	14	20,00	77	20	140	20.00X16.00	4	DIN 5156	NORMAL	C
MTH- 7/8-14G-BC-V045	G 7/8-14	-	14	22,00	85	20	150	22.00X18.00	4	DIN 5156	NORMAL	C
MTH- 1-11G-BC-V045	G 1-11	-	11	25,00	93	22	160	25.00X20.00	4	DIN 5156	NORMAL	C
MTH- 1.1/8-11G-BC-V045	G 1.1/8-11	-	11	28,00	101	22	170	28.00X22.00	4	DIN 5156	NORMAL	C
MTH- 1.1/4-11G-BC-V045	G 1.1/4-11	-	11	32,00	72	22	170	32.00X24.00	4	DIN 5156	NORMAL	C
MTH- 1.1/2-11G-BC-V045	G 1.1/2-11	-	11	36,00	87	23	190	36.00X29.00	4	DIN 5156	NORMAL	C

Пожалуйста, уточняйте наличие на складе действующую цену.

MTH-V023



- По режимам обработки см. стр. 276
- Покрытие TiN
- Материал HSS-PM

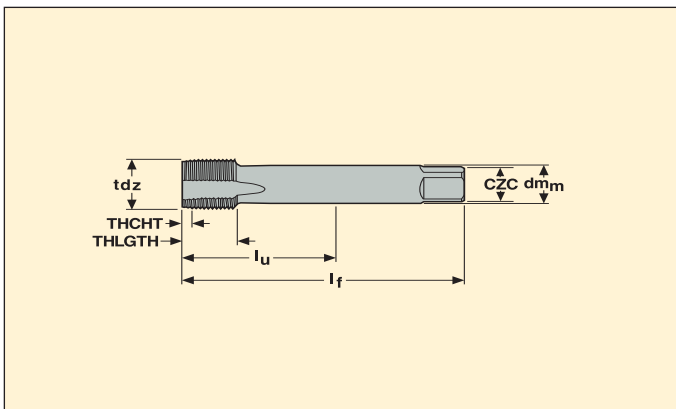

Обозначение	Резьба	Шаг		Размеры в мм					Число зубьев	BSG	tctr	THCT
		mm	TPI	dm _m	lu	THLGTH	lf	CZC				
MTH- 1/8-28G-TB-V023	G 1/8-28	–	28	7,00	67	17,6	90	7.00X5.50	3	DIN 5156	NORMAL	B
MTH- 1/4-19G-TB-V023	G 1/4-19	–	19	11,00	71	21	100	11.00X9.00	3	DIN 5156	NORMAL	B
MTH- 3/8-19G-TB-V023	G 3/8-19	–	19	12,00	58	21	100	12.00X9.00	4	DIN 5156	NORMAL	B
MTH- 1/2-14G-TB-V023	G 1/2-14	–	14	16,00	80	24	125	16.00X12.00	4	DIN 5156	NORMAL	B
MTH- 5/8-14G-TB-V023	G 5/8-14	–	14	18,00	78	24	125	18.00X14.50	4	DIN 5156	NORMAL	B

Пожалуйста, уточняйте наличие на складе действующую цену.